



MIKRON[®]

Infrared Temperature Transmitters
for Non-contact Temperature Measurement

Features

- 4 - 20mA linear output
- 2-wire connection
- Through-lens sighting (M67S)
- Variable focus distance (M67S)
- 0.5% accuracy
- Rugged Stainless Steel Design
- 2-year warranty



M67



M67S (through-lens sighting)

M67/67S Infrared Transmitters



Visit www.mikroninst.com

The M67, M67S Infraducers

The most dramatic design innovation (Patent No. 4,527,896) in non-contact infrared temperature measurement for process control in decades is now available in 2 different versions.

Innovative Design

The M67 and M67S Infraducers are 2-wire temperature transducers/transmitters for non-contact temperature measurement. The Infraducers represent the latest in innovative technology, integrating exclusive, advanced electronic design with optical and mechanical precision that are the essence of Mikron's infrared products. The design from concept to finish is based on simplicity of installation and maintenance. The Infraducers, with their matchless array of options and accessories, demonstrate Mikron's continuing leadership in infrared temperature measuring technology.

Universal Application

Completely self-contained, the M67 and M67S Infraducers can be used as true 2-wire temperature transducer/transmitters which produce a standard 4-20mA linear output. Powered by its current loop, each Infraducer is completely compatible with any existing instrumentation for recording or process control. A rugged, stainless steel housing, miniature size and light weight make the Infraducers suitable for many applications which up to now were the exclusive domain of contact type temperature transmitters, such as thermocouples, resistance thermometers, etc. To insure minimum maintenance and utmost reliability, the Infraducers have absolutely no moving parts. When contained within its companion cooling jacket and air purge assembly, each Infraducer can withstand the most punishing conditions found in industry. The Infraducers have universal application in virtually any type of industry. Typical application areas where infrared has successfully been used include: cement, ceramics, chemicals, food, glass, heat treating, metals, paper, plastics, power, printing, petrochemicals, robotics, rubber, semiconductors, textiles, vacuum systems....

Field Interchangeability

Superior design not only insures accuracy and long term reliability, it also insures interchangeability between Infraducers of the same model with $\pm 0.50\%$ accuracy. For especially demanding applications, the Infraducers have a digital emissivity control which can be set with a resolution of 0.01. This insures that, should one of the Infraducers need to be replaced, the replacement unit can be preset in every aspect before installation.

Application Assistance

Many years of experience in solving unusual and difficult infrared temperature measurement and control problems qualify our sales and application engineering staffs to offer solutions to the most challenging applications encountered in industry.

Quality Assurance

Reliability is never taken for granted at Mikron. After final calibration, every Infraducer is tested and burned-in for a week and rigorously subjected to a period of thermal cycling and vibration to verify calibration data.

Warranty

All Infraducers are covered by a two-year warranty period.

Made in U.S.A.

The M67 Series is designed and built by Mikron, the leading innovator in infrared thermometry.

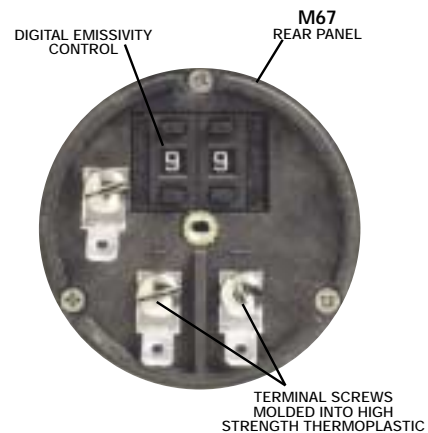

How to select the right *Infraducer*

There are two basic *Infraducer* shell designs, one for the standard **M67** and the other for the **M67S**. Each of these is available with a variety of temperature spans, spectral responses, and optical characteristics to meet specific applications. A large selection of efficient and heavy duty protective and mounting accessories is available to meet the customer's needs. **The Mikron protective jacket is recommended for all industrial applications.** The protective jacket allows more rigid installation of the *Infraducer* and minimizes the influence of ambient thermal transients. When dust and other contaminants are present, **the air purge assembly guarantees a clear viewing path for the optical system and mates directly to the Protective Jacket.** An auxiliary spring-loaded adjustable flange is also available when variable aiming capabilities are desired.

To order the right unit just follow these simple steps and insert the proper codes in the boxes below.

Step No.

- 1** Determine the desired *Infraducer* version based on focussing and application requirements. Place the desired model number in box No. 1. below.
- 2** Select the application requirements in the second column of the chart, select temperature range and units (F or C) from ranges listed across from your application. Insert ranges and units in boxes marked No. 2, filling in all blanks with zeros.
- 3** Insert in box No. 3, the spectral response code that is in line with the application and range previously selected.
- 4** If you selected either the M67, M67S or M67FM in box No. 1 insert code letter L in box No. 4 for 4-20mA linear output.
- 5** If you selected an M67 proceed to step 5A. If you selected an M67S proceed to step 5B.
- 5A** Read the section titled "Optical Resolution" for the M67 to the right. If standard factory focussing is acceptable, insert code S in box No. 5A. If other focussing distance is required insert code U in box No. 5A and specify desired focus distance and target size in writing. Proceed to step No. 6.
- 5B** Read the section titled "Optical Resolution" as it relates to the M67S. Determine the desired working distance of the instrument and insert the code number in box No. 5B. Proceed to step No. 6.
- 6** Specify desired initial factory output response time setting by inserting the proper code letter in box No. 6. Output response time is field adjustable should factory setting need to be changed. When code letter E is selected, specify in writing desired output response time. Refer to General Specifications for standard (code S) response time.
- 7** Designate the type of protective hardware required by code I for protective jacket without cooling capability or code J for protective jacket with cooling. Use of protective jacket in all cases where physical limitations do not exist is highly recommended. If no protective hardware is desired insert code letter O. (Not recommended for industrial applications.)

1 BASIC MODEL (See note 1.)	TYPICAL APPLICATION
<p>M67 WITH FIXED FOCUSING AND 4 – 20mA OUTPUT</p> <p>M67S WITH UPRIGHT THROUGH-LENS SIGHTING FOR VARIABLE FOCUSING AND 4 – 20mA OUTPUT</p> <p>M67FM INTRINSICALLY SAFE VERSION (AVAILABLE ONLY WITH STANDARD SPEED OF RESPONSE)</p>	MOST COMMON FOR LOW TEMPERATURE HIGH SENSITIVITY APPLICATIONS
	GENERAL PURPOSE APPLICATIONS INCLUDE TEXTILE, PRINTING, PAPER, FOOD, LAMINATING, RUBBER, THICK PLASTICS, PAINTS, ETC. REJECTS ENERGY FROM HIGH INTENSITY RADIANT HEATING SOURCES.
	LOW TEMPERATURE APPLICATIONS SPECIALLY SUITED FOR PLASTIC FILMS .004" (.1mm) OR THICKER, SEES THRU CALCIUM FLUORIDE WINDOW FOR VACUUM PROCESSES.
	THIN PLASTIC FILM SUCH AS POLYESTER, FLOURCARBONS, ETC. AND VERY THIN GLASS.
	THIN PLASTIC FILMS, i.e. POLYETHYLENE, POLYSTYRENE, POLYURETHANE AND POLYPROPYLENE.
	GLASS SURFACE MEASUREMENT APPLICATIONS INCLUDE, BENDING, FORMING, TEMPERING, ANNEALING, SEALING & LAMINATING, ETC.
	SEES THRU CLEAN FLAMES & HOT COMBUSTION GASES, APPLICATIONS INCLUDE, REFORMER TUBES, CHEMICAL REACTORS, KILNS, ETC.
	TEMPERATURE OF FLAME, FOR COMBUSTION AND POLLUTION INDUSTRIES, INCINERATORS, UTILITY BOILERS, KILNS, CHEMICAL REACTORS, ETC.
	MOST COMMON FOR HIGH TEMPERATURE APPLICATIONS SUCH AS METALS, FOUNDRIES, HARDENING, FORGING, ANNEALING, GLASS MELTING TANKS, GLASS GOBS AND SEMICONDUCTOR PROCESSES.
	MEDIUM TO HIGH TEMPERATURE APPLICATIONS FOR FERROUS AND NON FERROUS METALS, SEES THROUGH GLASS, FAST RESPONSE.
MEDIUM TO HIGH TEMPERATURE APPLICATIONS, FOR FERROUS AND NON FERROUS METALS.	

1

- 8** Select the air purge assembly when dust or other airborne contaminants are present. Specify code L for industrial air. (Instrument air is not required.) Specify code letter O if the air purge is not required. A protective jacket assembly is required for use of air purge.
- 9** In the box labeled 9 specify letter P if adjustable aiming flange is desired, O if not.

2 TEMPERATURE RANGE (See note 2.)		3 SPECTRAL RESPONSE		4 OUTPUT TYPE (4-20mA Linear)		FIELD OF VIEW RATIO
°F	°C	MICRONS	CODE	CODE		
■ -40-200	■ -40-100	7-20	A			15:1
■ 0-200	■ 0-100	8-14	B			15:1
0-500 0-1000 200-1800	0-300 0-500 100-1000	8-14	B			30:1
0-500	0-300	7-10	K			15:1
200-1000	100-500	7-10	K			30:1
■ 0-500	■ 0-300	7.9	F			15:1
200-800 300-1100	100-400 150-600	7.9	F			30:1
■ 120-400	■ 50-200	NARROW BAND CENTERED AT 3.43	M	4-20mA LINEAR	L	5:1
■ 200-600 300-1000	■ 100-400 150-500					8:1
200-1000	100-600	4.8-5.2	E			15:1
500-1500 500-2500	300-800 300-1300	4.8-5.2	E			30:1
■ 600-1800 800-2600 1200-3200	■ 300-1000 450-1450 600-1750	NARROW BAND CENTERED AT 3.86	D			30:1
600-2200 700-2500 800-3000 800-3500 1500-4000	320-1200 400-1400 450-1650 450-1900 800-2200			CO ² ABSORPTION BAND	L	
■ 900-1400 1100-1800 1200-2000	■ 500-800 550-900 600-1000	0.78-1.06	H			90:1
1300-2500 1800-3200 2000-4000 2700-5400	700-1300 900-1600 1100-2000 1500-3000	0.78-1.06	H			180:1
■ 450-800 500-1000	■ 220-400 300-600	1.0-1.6	Q			30:1
750-1400 1000-2200	400-800 500-1100	1.0-1.6	Q			90:1
■ 500-900 600-1000 700-1300 800-1600 1000-2200 1400-3000	■ 250-450 300-550 350-700 400-800 500-1100 750-1650	2.0-2.6	P			30:1

Notes:

1. *Infraducer* with M spectral band is only available in versions with fixed focussed distance and provides 0.75% FS accuracy
2. For these ■ ranges, *Infraducer* ambient temperature is limited to 0° - 50°C (32° - 122°F) and use of protective jacket is recommended.
3. **Minimum Target Sizes(MTS)** shown are based on 98% of energy received from target area.
4. *Infraducer* with M spectral band and target temperature less than 150°C (300°F) the response time is limited to 10 seconds and emissivity setting to minimum of 0.80.

5a M67 Focussed Distance		Code
Standard (Focussed at respective FOV ratio distance)		S
Optional (Specify desired focus distance in writing.)		U

6 Output Response Time (Field Adjustable)	
Code	Factory Setting
S	See Specs
A	300mSecond
B	1 Second
C	3 Seconds
D	10 Seconds
E	Others

7 Protective Jacket		Code
Without Cooling		I
With Cooling		J
NO		O

8 Air Purge Assembly		Code
YES		L
NO		O

9 Aiming Flange		Code
YES		P
NO		O

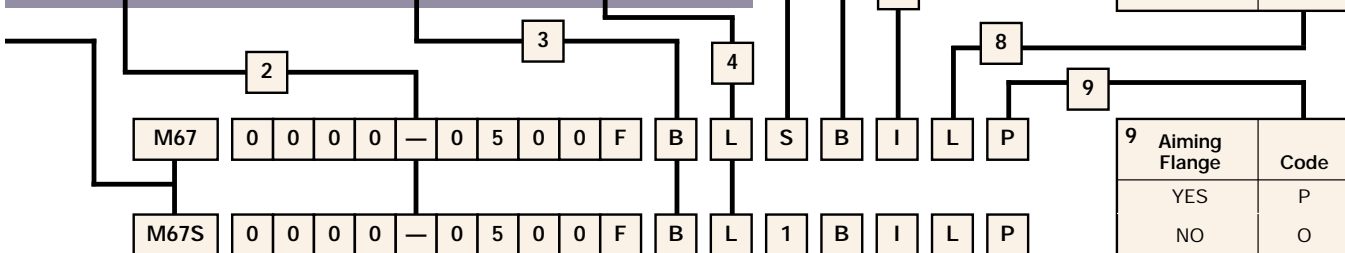

Example: Top model number shown above describes an M67 *Infraducer* for temperature range of 0 to 500°F with a spectral response of 8-14 microns, linear 4-20mA output, standard focus, output response time of 1 second, a protective jacket without cooling, air purge assembly for industrial air and aiming flange. Bottom number describes an M67S with through-lens sighting for variable focussing from 14" to infinity, with all other characteristics similar to the M67.

Optical Resolution — Fixed Focus

M67

The M67 features a fixed optical system in which the target size is determined by the distance between the target area and the sensor. The field of view of the instrument is determined by the spectral response and temperature range that you have already selected and has been pre-determined for you. The M67 is factory focussed for the most frequently used distances and follows its corresponding field of view diagram depicted in the chart to the right.

Close focus distances are available to facilitate accurate measurements of target areas smaller than 1" (25mm). Minimum target size is determined by the formula:

$$\text{Min. Target Size} = \frac{\text{Focussed distance (M67 to target)}}{\text{Field of View Ratio}}$$

A typical close focussing example and corresponding field of view diagram are shown below.

Example: Determine minimum target size for focus distance at 6" and FOV ratio of 30:1

$$\text{Min. Target Size} = \frac{6''}{30} = 0.2'' \text{ or } \frac{15\text{cm}}{75\text{cm}} = 5\text{mm}$$

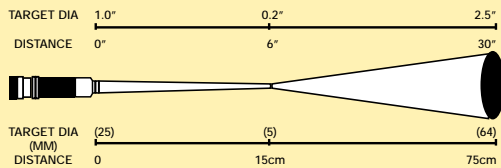

(Minimum focusable distance for each FOV is shown to the right.)

Standard Field of View (FOV) Diagrams (see note 3)

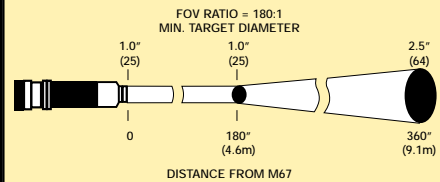
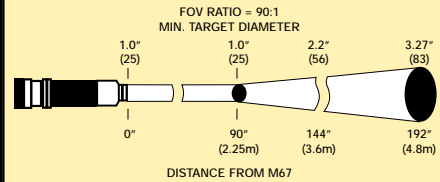
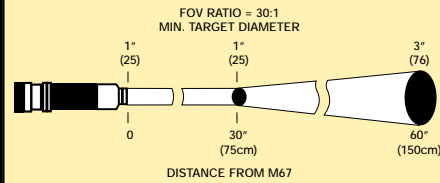
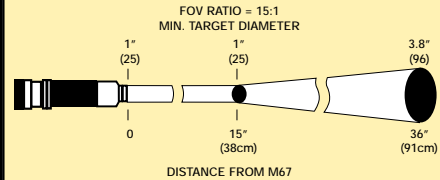

Min. Focusable Distance for Close Focus

2" (5cm)

2" (5cm)

6" (15cm)

14" (35cm)

Optical Resolution—Variable Focus M67S

Three different lenses are available for the M67S. The one you should choose depends on the desired working distance of the unit. The first version is designed to measure temperature at distances of 14" to infinity. The second version has a working distance of 6" to 14". The third version is fixed to measure temperatures at a 2" distance. Proper focussing is achieved by mounting the unit at the desired distance and adjusting the focussing knob on the rear panel of the instrument until the target comes into clear view in the reticle. When the target is in focus to the eye, it is also in focus to the detector. Should you wish to move the instrument, remember to stay within the prescribed working distance, and simply refocus upon the target after mounting the instrument in its new location.

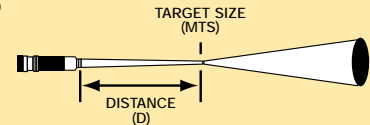

A typical field of view diagram is shown at right:

$$\text{Formula to determine Minimum Target Size: (MTS)} = \frac{\text{Focussed Distance (D) (M67S to target)}}{\text{Field of View Ratio}}$$

$$\text{Example: M67S, version 1 with 30:1 FOV focussed at 15"} \quad \text{(MTS)} = \frac{D}{\text{FOV}} = \frac{15}{30} = 0.50''$$

Minimum target sizes are shown in the table below

Field of View	Version 1 Focus 14" to infinity	Version 2 Focus 6" to 14"	Version 3 Focus at 2"
15:1	Min target of 0.93" at 14" distance	Min target of 0.40" at 6" distance	Min target of 0.13" at 2" distance
30:1	Min target of 0.47" at 14" distance	Min target of 0.20" at 6" distance	Min target of 0.06" at 2" distance
90:1	Min target of 0.16" at 14" distance	Min target of 0.07" at 6" distance	Not Available
180:1	Min target of 0.07" at 14" distance	Not Available	Not Available

5b

M67S Operating Distance	Code
14" (350mm) to Infinity	1
6" (150mm) to 14" (350)	2
2" (50mm) Fixed	3

General Specifications

Accuracy:** $\pm 0.50\%$ of full scale or 1.0°C (1.8°F) whichever is greater.

Resolution: $\pm 0.1\%$ of full scale span (FSS)

Repeatability: $\pm 0.2\%$ of full scale span (FSS)

Emissivity: Digital setting 0.10 to 0.99 with 0.01 step

Optical System: M67S: Non-parallax refractive optics focusable from rear panel.

Field of View: M67S: Visual sighting 4° . Infrared measurement definition MTS see FOV diagram for M67 and optical resolution for M67S.

Focussing Distance: M67S: 3 different versions cover $2''$ to infinity (adjustable for sharp focussing on target).

Eye-piece: M67S: Diopter type

Input Voltage: 24VDC nominal

Input Voltage Range: 18-40VDC

Output Current Span: 4-20mA linear standard

Minimum Output Current 3.8mA

Maximum Output Current 32mA

Response Time: 50mS for codes H and Q spectral response, 100mS for all others. Response time defined as time required for output to reach 95% of its final value.

Load Resistance Max: 400 ohms for 24VDC input voltage, 1200 ohms for 40VDC input voltage.

Electrical Connections: 1) M67 — Two terminal screws molded into high strength, high temperature thermoplastic 2) M67S — Four terminals compression type.

Operating Ambient Temperature:

Without Cooling Jacket: 0° to 60°C (32° to 140°F).

With Air Purge Assembly: 120°C (250°F) rated for water cooling.

With Cooling Jacket: Up to 315°C (600°F).

Storage Ambient Temperature: -30° to 80°C (-20° to 160°F)

Relative Humidity: 90% Non-condensing

Vibration: M67 — 3 g's any axis continuous

Shock: M67 — 50 g's

Housing Material: Stainless steel

Dimensions: 1) M67 — 2.0" dia. x 7.8" long (50mm x 200mm)

2) M67S — 2.0" dia. x 8.0" long (50mm x 203mm)

Weight: 1.9 lbs. (0.90kg)

Mounting: Support block with four 0.200" (5mm) dia. holes and "U" clamp. For more secure mounting, use of protective jacket is recommended.

Optional Features:

NIST Traceable Calibration Certificate: Minimum of five points on instrument temperature scale. Additional points as required at extra cost per point.

FM Approved Version: See Basic Model selection chart.

Peak/Valley Picker: See accessories (electrical).

** 1. Accuracy is stated for target emissivity of 1.0 at specified focussed distance and target having sufficient diameter to eliminate background influence.

** 2. Accuracy is stated for input voltage of 24VDC and load resistance of 250 ohms.

** 3. For *Infraducer* with M spectral band accuracy is limited to 0.75% FS.

Accessories (Mechanical)

Protective Jacket and End Cap

The cast aluminum jacket and end cap protects the *Infraducer* from physical damage when located in environments of heavy industry and also dampens the effect of rapid ambient changes. The precision machining of the protective jacket allows for easy removal and replacement of the sensor head with no loss of alignment. In high ambients when temperature exceeds the maximum rated temperature of the *Infraducer*, the use of a protective jacket with cooling capability is mandatory. Extensive research and testing of the jacket

assures uniform cooling along its entire length and simultaneously isolates the *Infraducer* from thermal influence. While air flow alone is sufficient for light cooling, water must be used for moderate or heavy cooling.

Ambient Temp.		Gal./HR	Liters/Hrs.
$^{\circ}\text{F}$	$^{\circ}\text{C}$		
150	65	0.2	0.8
200	95	0.6	2.3
250	120	1.0	3.8
300	150	2.0	7.6
350	175	3.0	11.4
400	205	4.0	15.2
450	230	6.0	22.7
500	260	10.0	37.8
600	315	20.0	76.0

Inlet coolant temperature assumed at 68°F (20°C).

Air Purge and cooling Assembly

Though simple in outward appearance, this assembly performs three very important functions—purging, aiming and localized cooling. Air purging of the optics is extremely important when airborne contaminants can build up on the lens and eventually "blind" the sensor head.

In contrast to many air purge systems currently in use which actually develop a negative pressure vortex and contribute to the build up of contaminants, the Mikron air purge assembly has been carefully engineered to prevent this build-up from occurring. **A flow of only 75 CFH (2 CMH) of normally clean industrial air will keep the optics clean under most conditions.**

The metal sight tube is designed for installations where it is desirable to augment the air purge and facilitate approximate aiming of the *Infraducer*.

The cooling plate section of the air purge assembly allows the coolant to circulate in a stainless steel chamber which allows cooling of *Infraducer* up to ambient temperature of 120°C (250°F). **The air purge assembly depends upon the protective jacket for mounting.**

Aiming Flange Assembly

For installations requiring durable mounting of the sensor head while allowing for adjustment of the optical path to a maximum of $\pm 5^{\circ}$ in any direction from normal to the mounting plate. Specify PN 11649-2 when ordered separately.

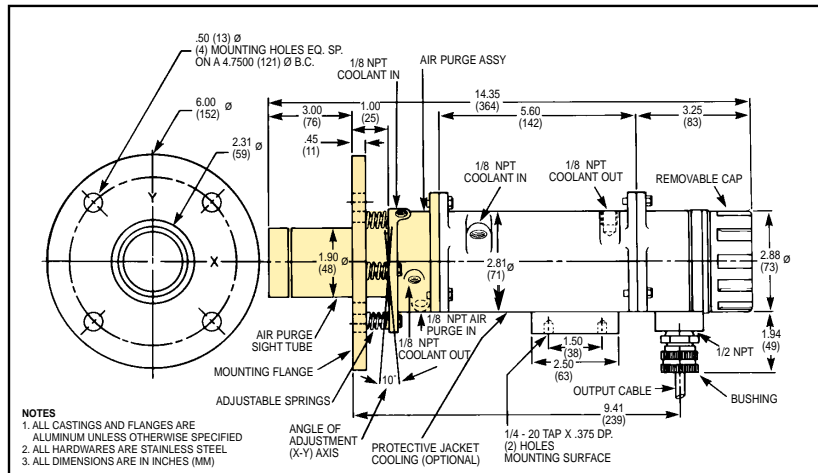
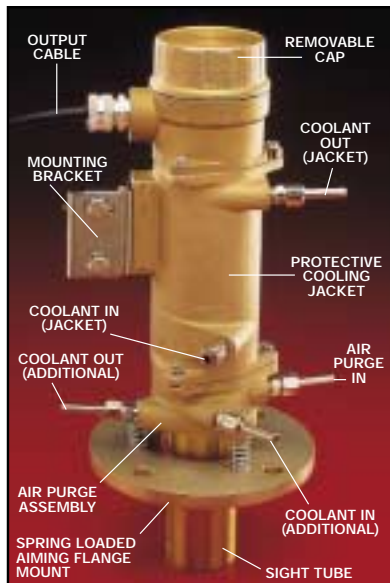

Infraducer Models

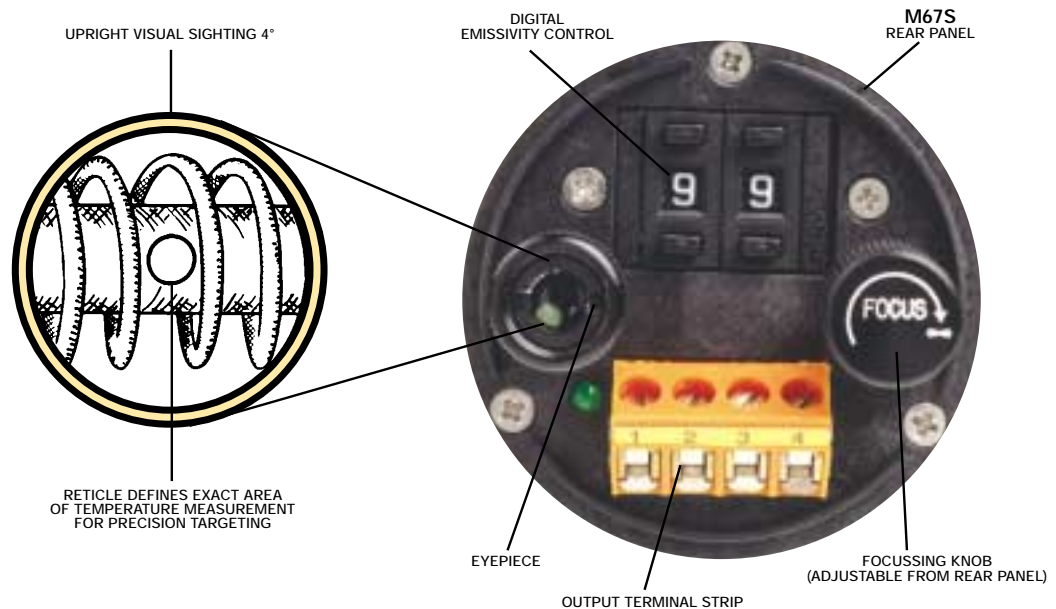

M67 Infraducer

The M67 is designed to handle most demanding industrial applications. When powered by an 18 to 40VDC supply, it provides a 4-20mA linear output for interface with indication and recording instrumentation. Its two-wire design simplifies installation, operation and maintenance. Screw terminals allow easy yet secure connection. The M67 has a fixed optical system. That is, target size is determined by the distance between the sensor and the target area. It is recommended for applications where target size is known and operating distance is relatively constant.

M67S Infraducer

The M67S contains all the features of the M67 with the added benefit of upright through-lens sighting. The M67S incorporates a high quality, high precision variable focus optical system that allows sharp focussing on the desired target from 2" to infinity. Focussing is executed by turning the

focussing knob on the rear panel of the instrument. The M67S allows for precision pinpointing of small target areas. The user simply adjusts the instrument until the image is clear and the desired target is located within the reticle.

The M67S is available in three distinct versions. The first will make accurate measurements at distances of 14" to infinity, the second has a working range of 6" to 14" and the third is designed to measure a target at 2" distance. See the M67 Optical Resolution Selection Guide for details.

FM Approved Model

The model M67FM Infraducer has been approved by Factory Mutual (FM) for usage in hazardous environments. When used in conjunction with the optional barriers, the entire system will be rated intrinsically safe. Approvals are for Class I, II, and III, Division 1, Group A, B, C, D, E, F, and G. At the time of order please specify that the FM approved version is required.

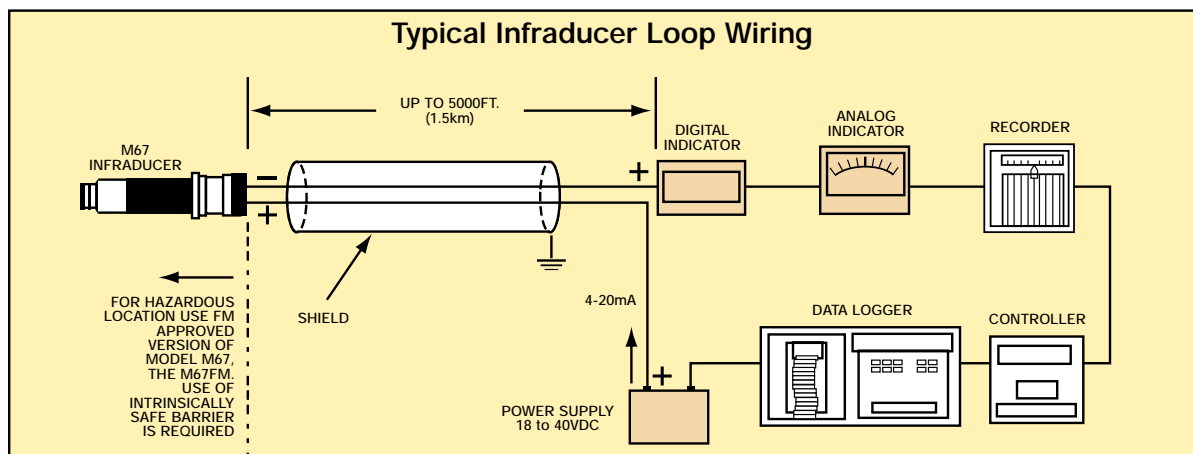

NIST Traceable Calibration Certificate

Mikron infrared thermometers are supplied with a standard calibration certificate at no charge. The additional assurance of a calibration certificate traceable to National Institute of Science and Technology (NIST), is optionally available at additional cost. Please refer to Options in the Specifications.

Accessories (Electrical)

Peak/Valley Picker

The M67 with optional built-in peak/valley picker circuitry allows a fast response to temperature rise and adjustable slow decay of output when temperature falls. This feature is invaluable in applications where wide temperature variations are encountered.

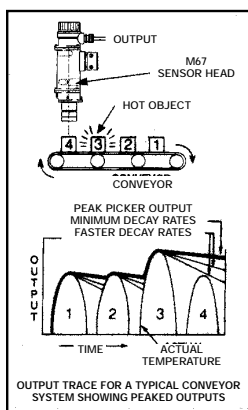

M67EM Electronic Module

The M67EM is a basic electronic module designed to support the M67/M67S Infraducer on those installations where a remote peak/valley picker is the dominant electronic requirement. The M67EM operates from 115VAC (220VAC optional) and provides a 24 VDC voltage for a 2-wire 4-20mA loop connection.

M67EM Specifications

Input Signal Requirements: 4-20mA linear from M67/M67S output

Response Time Adjust: 10mS to 10 sec. Field adjustable

Peak/Valley Picker Decay Rate: (Valley Picker optional) Manually adjustable between 0.01 and 10% of full scale/second.

Peak Picker Controls: (Valley Picker optional) On, Cancel and Reset from front panel. Remote Reset actuated by external SPST switch (customer supplied).

Standard Outputs (Linear): 0-1VDC full scale; 0-50mVDC full scale; 1mV/°F or C; 4-20mADC, 650 ohms max.

Output Supply Voltage: +24VDC to power M67/M67S

Ambient Temperature Range: 0°C to 50°C (32°F to 120°F)

Size: 64mm(W) x 128mm(H) x 230mm(D) (2.5 in. x 5.0 in. x 9.0 in.)

Panel Cutout: 58mm x 108mm (2.25 in. x 4.25 in.)

Power: 115VAC ±10% 50/60Hz (220VAC optional) 30 watts max.



Precision Digital Process Meters

Mikron M60TDS

The M60TDS digital process meter has a 4 digit, 0.56" high LED display with front panel keyboard programmability. It provides monitoring and display of the minimum and maximum process value input with keypad reset as a standard feature. The M60TDS contains a built-in 24VDC power supply which simplifies connection to the Infraducer.

For more information about any of these meters, please contact Mikron Sales Department.

Other Mikron Products include: M67LR Laser Sighted Infraducer, M68 Fiber Optic Version of M67.

Power Supplies

These power supplies provide either a 24 or 40VDC to power the sensor head. The low profile, sealed and rugged package is designed for chassis mounting. The front-mounted terminal barrier strip is perfect for isolation between input and output voltages. A current limiting feature protects the power supply when short circuit occurs. Four tapped holes are provided for mounting. Available in both 115 and 230VAC versions.



Input Voltage ±10% 50-60Hz	Output Voltage	Max. Load Current	Part No.
115VAC	24VDC	100mA	11846-1
230VAC	24VDC	100mA	11846-3
115VAC	40VDC	100mA	11846-2
230VAC	40VDC	100mA	11846-4



Mikron Instrument Company Inc., Headquarters
16 Thornton Road
Oakland, NJ 07436 USA
Tel: 201-405-0900
Tel: (USA only) 800-631-0176
Fax: 201-405-0090
E-mail: sales@mikroninst.com

West Coast Office:
Mikron
4475 Dupont Court #9
Ventura, CA 93003
Tel: 805-644-9544
Fax: 805-644-9584
E-mail: sales@e2t.com

Visit our websites: www.mikroninst.com
www.IRimaging.com