

LORD Balancing Systems

For Centrifugal Induced Draft/Forced Draft and Axial-Van Fans

LORD Fan Balancing Systems are comprised of sensors, a controller and one or more balancers that make trim balance corrections to reduce fan vibration while the fan is running, at any operating speed or load. The system is able to compensate for variable balance conditions due to material build-up, temperature variations and changing process conditions. Balance corrections can be made automatically, minimizing vibration caused by unbalance in seconds.

Features & Benefits

Cost Effective – reduces downtime and increases productivity. Trim balances equipment while operating, without a forced shutdown. Eliminates multiple starts and stops necessary for manual balance correction. Provides rapid payback on balancing system and installation cost.

Efficient – optimizes equipment life (bearings, motors, seals, etc.).

Adaptable – fits with existing condition monitoring systems. Operates in either automatic or manual modes.

Versatile – maximizes asset availability.

Reliable – performs continuous monitoring and diagnostics, on-site or remote. Eliminates unscheduled maintenance.

Fail-Safe – maintains last correction, even if power is lost.

How the Balancing System Works

One or more balancers are permanently fixed on the shaft of the fan. Each balancer is surrounded by a stationary coil used to transmit power into the balancer(s).

Sensors monitor vibration levels and transmit information to the controller. When vibration levels exceed a preset high-limit, the controller signals the coil(s) to pulse power to the balancer(s) to make a balance correction.

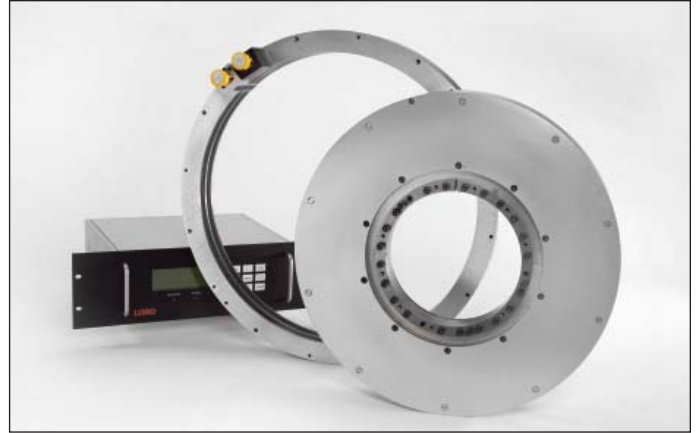

LORD Balancing System

The correction is made by the repositioning of two counterweighted rotors relative to each other, located inside the rotating balancer(s).

Vibration levels are reduced as the rotors are moved, until the controller senses that vibration levels have dropped below a preset low-limit.

The rotors are repositioned in seconds to complete the trim balance correction, while the fan continues operating without a forced shutdown.

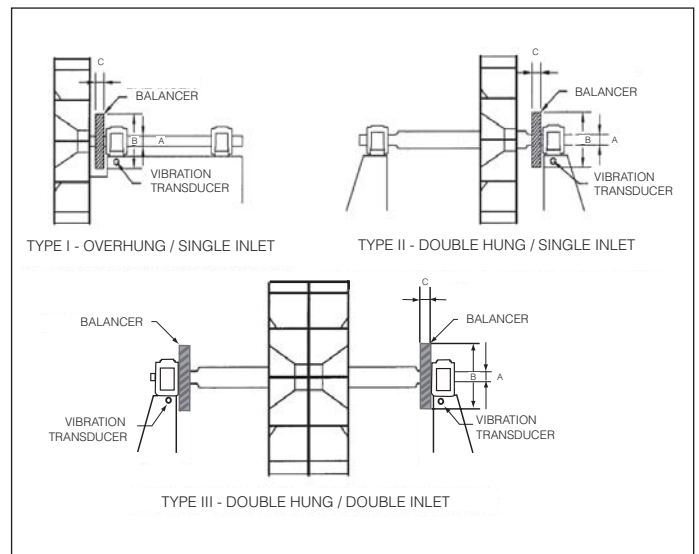

LORD PRODUCT INFORMATION

LORD Balancing System Components

The LORD balancing system uses inputs from a vibration sensor and phase reference sensors to determine the magnitude and phase angle of vibration in the fan. Once this data is processed in the control system and an out of balance condition occurs, a signal is sent from the controller to the power amplifier which, in turn, sends power in controlled pulses into the stationary coil assembly. The coil assembly then transmits this power across an air gap into the balancer assembly and repositions the balance weights to the optimum position to minimize the fan vibration. This process takes place automatically, while the fan is running.

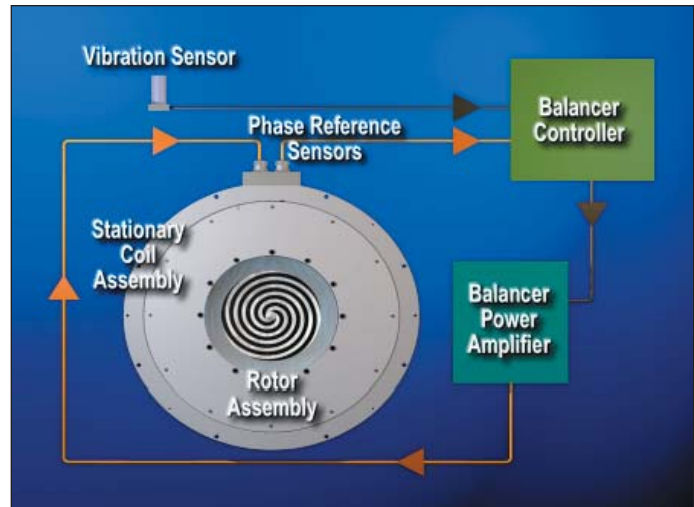

Windows Interface Software

Windows-based software provides graphical interactive displays of the LORD Balancing System. The software is continuously updated to show current equipment vibration levels and stores unbalance history along with past balance correction data. In addition, the software measures and indicates the amount and location of correction capacity used.

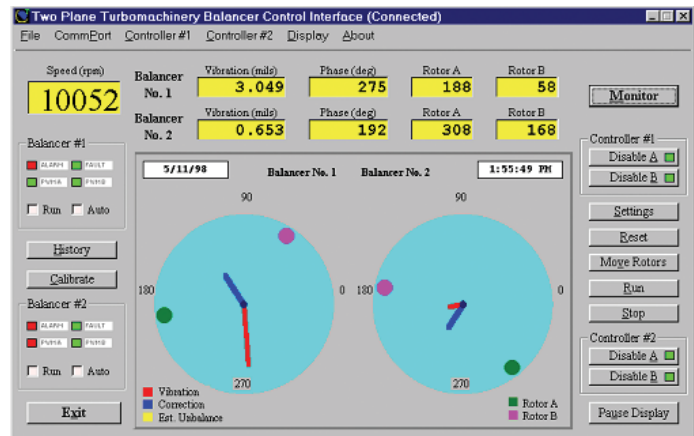

"Ask Us How" is a trademark of LORD Techmark, Inc., a subsidiary of LORD Corporation.

LORD provides valuable expertise in adhesives and coatings, vibration and motion control, and magnetically responsive technologies. Our people work in collaboration with our customers to help them increase the value of their products. Innovative and responsive in an ever-changing marketplace, we are focused on providing solutions for our customers worldwide . . . Ask Us How.

LORD Corporation
World Headquarters

111 Lord Drive
Cary, NC 27511-7923
USA

Customer Support Center
+1 877 ASK LORD (275 5673)

www.lord.com